

## Operating Principle

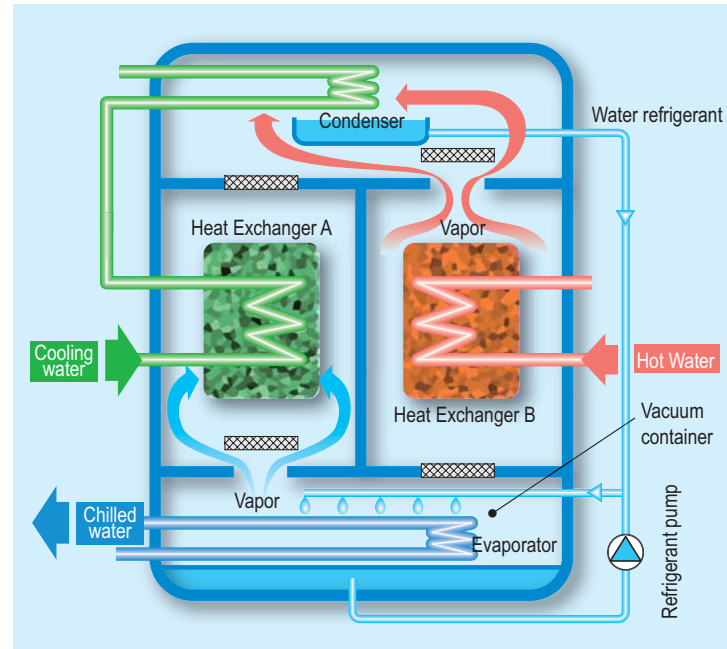

AdRef-Noa consists of two identical adsorption / desorption heat exchanging sections, one for each evaporative and condensing heat exchanger. Adsorption-desorption process, described below, is interchanged and repeated in these two sections.

### ADSORPTION

Water as a refrigerant evaporates in the evaporative heat exchange section. AdRef produces chilled water by using evaporative latent heat. The vapor is then adsorbed by an adsorption heat exchanger A. The heat exchanger generates heat, but removing this heat by cooling water further enhances the evaporating process.

### DESORPTION

Hot water (the heat source) is used to remove the moisture that is adsorbed in the adsorption heat exchanger B. The released moisture enters the condensing section and is condensed for next evaporation.

## Standard Specifications

Items		models		
		Z-3515	Z-3525	Z-6025
Cooling Capacity	kW [Btu/h]	105 [358,260]	215 [733,580]	430 [1,467,160]
	Chilled water outlet temp. °C [°F]	15 [59]	15 [59]	15 [59]
Chilled water	flow rate m <sup>3</sup> /h [GPM]	12.1 [53.3]	24.3 [107]	48.7 [214.4]
	Heat source inlet temp. °C [°F]	68 [154.4]	68 [154.4]	68 [154.4]
Heat source	flow rate m <sup>3</sup> /h [GPM]	20 [88.1]	40 [176.1]	80 [352.3]
	Cooling water inlet temp. °C [°F]	27 [80.6]	27 [80.6]	27 [80.6]
Cooling water	flow rate m <sup>3</sup> /h [GPM]	50 [220.2]	99 [435.9]	198 [871.9]
	Refrigerant pump kW [HP]	0.3 [0.4]	0.55 [0.7]	1.1 [1.5]
Vacuum pump	kW [HP]	0.4 [0.5]	0.4 [0.5]	0.75 [1.0]
Outer Dimensions	L mm [inch]	3,700 [145 5/8]	3,700 [145 5/8]	6,100 [240 1/8]
	W mm [inch]	1,500 [59]	2,450 [96 1/2]	2,450 [96 1/2]
	H mm [inch]	2,800 [110 1/4]	2,800 [110 1/4]	2,800 [110 1/4]
Net weight	kg [lbs]	6,600 [14,550]	10,000 [22,046]	15,000 [33,069]

## Performance comparison between models

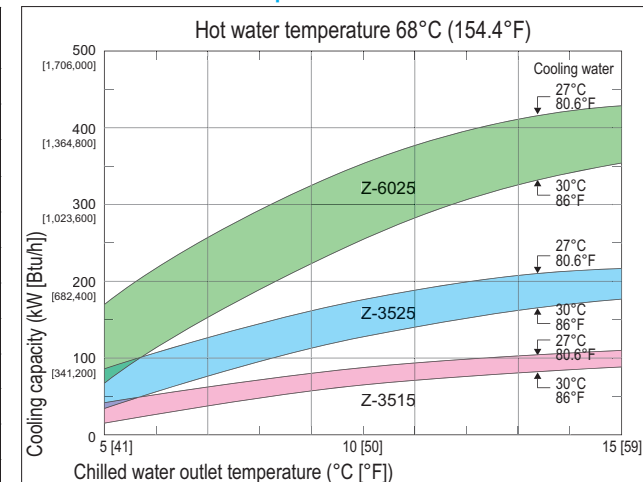

<Standard design conditions> Provided hot water temperature: 60~80°C (140~176°F)  
Chilled water outlet temperature: 5~25°C (41~77°F)  
Cooling water inlet temperature: 32°C (89.6°F) or less  
\*Contact us for other conditions.

## Outer Dimensions

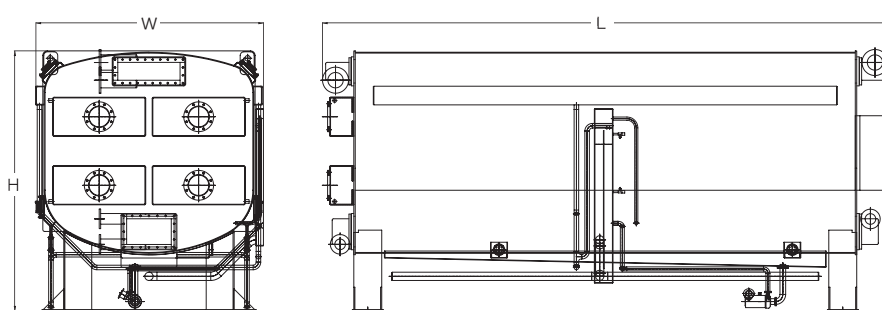

\* This product is commercialized by the project "Research and Development of Technologies for New Solar Energy Utilization Systems" of New Energy and Industrial Technology Development Organization (NEDO) in Japan.

**MAYEKAWA**  
**MYCOM**

www.mycanada.com  
www.mayekawausa.com  
www.mayekawa.com

Natural is what we design for!

Vancouver, BC  
Toronto, ON  
Chicago, IL  
Torrance, CA  
Modesto, CA  
San Francisco, CA  
San Antonio, TX  
Houston, TX

Phone: 604-270-1544  
Phone: 905-564-0664  
Phone: 773-516-5070  
Phone: 310-328-1362  
Phone: 209-545-9752  
Phone: 650-378-1235  
Phone: 210-599-4536  
Phone: 281-447-2599

York, PA  
New York, NY  
Seattle, WA  
Charlotte, NC  
Miami, FL

Phone: 717-779-0138  
Phone: 914-301-9770  
Phone: 425-348-3404  
Phone: 704-896-3632  
Phone: 305-477-5741

**MAYEKAWA**  
**MYCOM**

# AdRef-Noa

## Adsorption Chiller with Zeolite

Utilizing renewable energy:  
low temperature heat such as solar heat and waste heat



**HCFC/HFC/CFC free chiller, AdRef-Noa**  
Friendly to mankind and to the earth

# The 21st century business model

Providing chilled water by utilizing 60~80°C (140~176°F) hot waste water

# The ultimate act to reduce CO2 emissions! Expand the possibility of using renewable and unused energy!!

■ Examples of heat sources ... solar heat, hot springs, geothermal, combined heat and power, fuel cells, waste heat from industrial furnaces / distilling columns / reactor towers / district heating networks / etc...

## ■ FEATURES

### Minimizing Life Cycle Cost

- ① HCFC/HFC free
- ② Energy-saving
- ③ Lower operation and maintenance costs
- ④ No noise and no vibration
- ⑤ No certified operator required

### ■ The comparison of cooling capacity

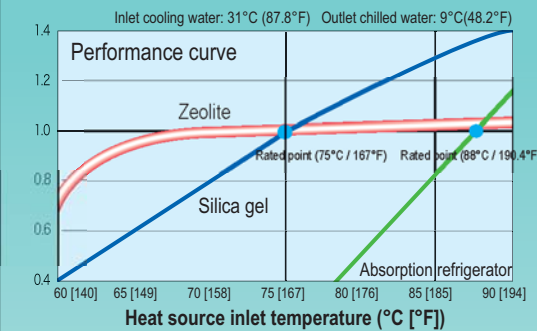

## ■ EFFECTS

### Achieving COP 10 \*Electricity COP

### ■ The system comparison in 100USRT scale

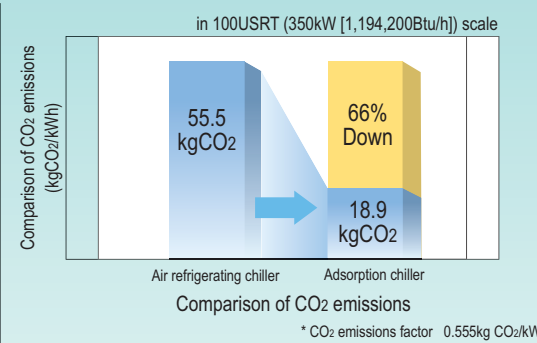

	<Air refrigerating chiller>	<Adsorption chiller>
Driving power	100kW (134HP)	1.1kW (1.5HP)
Cooling tower fan		16.5kW (22.1HP)
Cooling water pump		11kW (14.8HP)
Hot water pump		5.5kW (7.4HP)
<b>Total</b>	<b>100kW (134HP)</b>	<b>34.1kW (45.8HP)</b>

Renewable energy (Solar heat, Hot springs, Geothermal, etc.)  
Use solar light and heat to achieve HCFC/HFC/CFC free air conditioning.

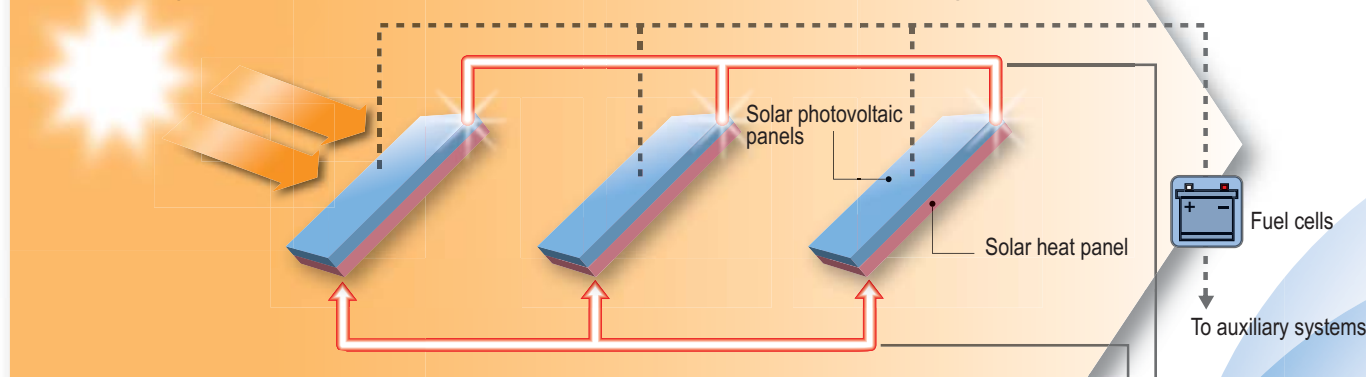

Biomass Energy (Forest thinning, Scrap wood, Food waste, Sewage sludge, etc.)  
Convert industrial waste into biomass energy to achieve zero-emission plants.

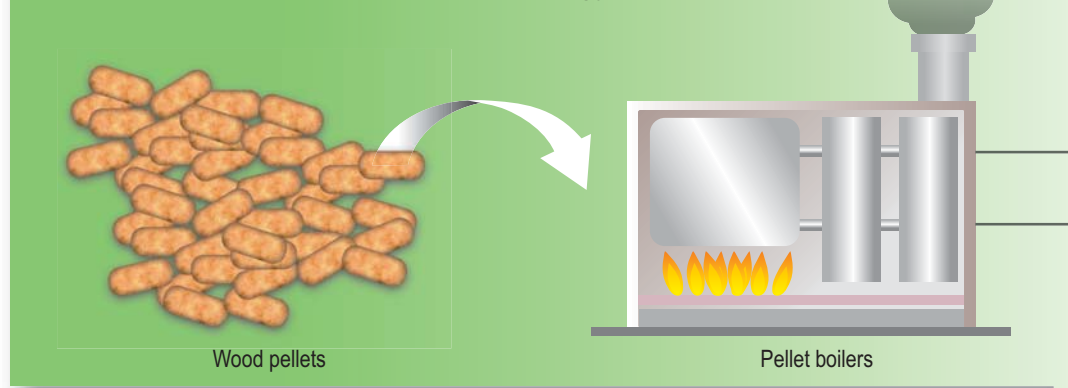

Unused energy (Waste heat from plants, Combined heat and power (CHP), Waste heat from industrial furnace, etc.)  
Produce chilled water from unused heat source to eliminate existing HCFC/HFC/CFC chillers for green solution.

